



**air-o-steam
Touchline
Natural Gas Combi Oven 20GN 2/1**

ITEM # _____

MODEL # _____

NAME # _____

SIS # _____

AIA # _____



air-o-steam

Touchline Natural Gas Combi Oven 20GN 2/1

267785 (AOS202GTW1)

air-o-steam with high resolution touch screen control, gas, 20x2/1GN, 3 cooking modes (automatic, recipe program, manual), air-o-clima and air-o-clean functions with boiler in 316L - UK, Middle East

condensation avoiding wet floors. Halogen lighting in the cooking chamber. Side panels and interior in AISI 304 stainless steel. Supplied with n.1 trolley rack 2/1GN, 63mm pitch and door shield.

Short Form Specification

Item No. _____

Convection-steamer with a high resolution touch screen control panel (translated in 30 languages).

air-o-clima: real humidity control based upon Lambda sensor for consistent results independent from the food load. With hot air cycles air-o-clima exhausts any excess humidity generated by the food. A dedicated steam generator guarantees a continuous supply of steam at all times. Manual injection of water to add additional moisture in the cell. Boiler in 316L to protect against corrosion.

air-o-flow: fresh air is blown into the oven from the outside, after it is pre-heated it is pulled through the bi-functional fan, guaranteeing cooking evenness.

air-o-clean: built-in cleaning system with four automatic pre-set cycles. Green cleaning functions can be set to save energy (skip drying function), water (reduce water consumption) and rinse aid (skip rinse aid).

Three cooking modes: Manual (cooking cycle, temperature, time and advance features); Automatic - (select family and food type + 3 special cycles-LTC, proofing, regeneration); Programs (recipe selection from page with 1000 free 16-phase programs and search button). Recipes can be saved in a USB key for replication in other ovens.

Automatic pre-heating and pre-cooling. Half power, half speed and pulse ventilation controls. Food probe with 6 temperature sensors (the lowest one drives the cycle). Double-glass door with book-like opening maintains a cool external temperature and incorporates a drip pan to collect excess

APPROVAL: _____



air-o-steam
Touchline Natural Gas Combi Oven 20GN 2/1

Main Features

- Guided descaling function to guide operator during boiler descaling phase (from "Setting" mode).
- MultiTimer function to manage a sequence of up to 14 different cooking cycles, improving flexibility and ensuring excellent cooking results. Can be saved up to 70 multitimers programs.
- air-o-clean™ automatic and built-in self cleaning system (4 automatic and green functions to save energy, water and rinse aid).
- Automatic mode: choosing family and food type, the oven automatically selects the appropriate cooking climate, temperature and time. A maximum of 60 personalised presets per family can be saved. Three special automatic cycles available:
 - Low Temperature Cooking cycle (LTC) to minimize weight loss, maximizing food quality for large pieces of meat.
 - Reheating cycle: efficient humidity management to quickly reheat.
 - Proofing cycle: uses the air-o-clima function to create the perfect proofing conditions.
- Programs mode: a maximum of 1000 recipes can be stored in the oven's memory, to recreate the exact same recipe at any time. The recipes can be group in 16 different categories to better organize the menu. 16-step cooking programs also available.
- Manual mode: traditional cooking style by manually selecting the parameters. Traditional cooking cycles available:
 - Dry, hot convection cycle (max. 300 °C): ideal for low humidity cooking.
 - Low temperature Steam cycle (max. 100 °C): ideal for sous-vide (vacuum packed) re-thermalization and delicate cooking.
 - Steam cycle (100 °C): seafood and vegetables.
 - High temperature steam (max. 130 °C).
 - Combination cycle (max. 250 °C): combining convected heat and steam to obtain humidity controlled cooking environment, accelerating the cooking process and reducing weight loss.
- air-o-clima™: Lambda sensor controlled automatic humidity adjustment of cooking environment.
- air-o-flow: fresh air from the outside is directed to the bi-functional fan, becomes pre-heated and then pushed into the cooking chamber to guarantee an even cooking process.
- 6-point multi sensor core temperature probe for maximum precision and food safety.
- Fan speeds: full, half speed for delicate pulse cooking such as for baking cakes and pulse ventilation for baking and low temperature cooking. The "pulse utility" is also perfect for keeping food warm at the end of the cooking cycle.
- Reduced power cycle.
- USB connection: to download HACCP and FSC data, upload the recipes and interface setting.
- Food safe control monitors the cooking process to comply with HACCP standards. HACCP management to record cooking procedure available upon request.

- Sous-vide USB probe to ensure excellent cooking results even with vacuum-packed products (optional accessory).
- Make-it-mine feature to allow user to personalize all user main interfaces in the "Setting" mode and block editing and deleting of stored programs.
- Integrated Automatic Intensive Cleaning System: enhanced cleaning parameters and wash arms design to optimize detergent, rinse aid and water use thus obtaining superior cleaning results.

Construction

- IPX 5 spray water protection certification for easy cleaning.
- 304 AISI stainless steel construction throughout.
- Seamless hygienic cooking chamber with all rounded corners for easy cleaning.
- Double thermo-glazed door with open frame construction, for cool outside door panel. Swing hinged easy-release inner glass on door for easy cleaning.
- Swing hinged front panel for easy service access to main components.

Included Accessories

- 1 of Trolley with tray rack for 20x2/1GN ovens and bcf, 63mm pitch PNC 922044
- 1 of Control panel filter for 20xGN2/1 ovens PNC 922249

Optional Accessories

- WATER SOFTENER WITH CARTRIDGE STEAM 1200 PNC 920003
- Automatic water softener for ovens PNC 921305
- Resin sanitizer for water softener PNC 921306
- Pair of 1/1 GN AISI 304 grids PNC 922017
- Couple of grids for whole chicken 1/1GN (8 per grid) PNC 922036
- Trolley with tray rack for 20x2/1GN ovens and bcf, 63mm pitch PNC 922044
- Trolley with tray rack for 16x2/1GN ovens and bcf, 80mm pitch PNC 922046
- Thermal blanket for 20x2/1GN PNC 922049
- Trolley with banquet rack 92 plates for 20x2/1GN ovens and bcf, 85mm pitch PNC 922055
- Pastry trolley for 20x2/1GN ovens and bcf, 80mm pitch (16 runners). Suitable for 600x400mm pastry trays in oven PNC 922069
- DOOR SHIELD 20 2/1-PRE-HEAT W/O TROLLEY PNC 922095
- Side external spray unit (needs to be mounted outside and includes support for mounting to oven) PNC 922171
- Pair of 2/1GN aisi 304 stainless steel grids PNC 922175
- 2 fat filters for 20 1/1 and 2/1 GN combi steamers (gas and electric) and convection ovens (electric) PNC 922179
- Baking tray with 5 rows (baguette), perforated aluminium with silicon coating (400x600x38) PNC 922189
- Baking tray with 4 edges, perforated aluminium (400x600x20) PNC 922190
- Baking tray with 4 edges, aluminium (400x600x20) PNC 922191
- Basket for detergent tank - wall mounted PNC 922209



- Flue condenser for gas ovens PNC 922235
- 2 frying baskets for ovens PNC 922239
- Heat shield for 20x2/1GN PNC 922242
- Retractable spray unit for 20GN1/1&2/1 ovens PNC 922263
- Grid for whole chicken 1/1GN (8 per grid - 1,2kg each) PNC 922266
- Kit integrated Haccp for ovens PNC 922275
- Kit to convert from natural gas to LPG PNC 922277
- Adjustable wheels for 20x1/1 and 2/1GN ovens PNC 922280
- USB probe for Sous-Vide cooking - available on EasySteamPlus and EasyPlusT ovens with software versions after 4.10 PNC 922281
- Kit universal skewer rack and 6 short skewers for Lengthwise and Crosswise ovens PNC 922325
- Universal skewer rack PNC 922326
- 6 short skewers PNC 922328
- Fat collection tray 40 mm PNC 922329
- Smoker for lengthwise and crosswise ovens - 4 kinds of smoker wood chips are available on request PNC 922338
- Water filter for ovens - 4 membranes PNC 922344
- External reverse osmosis filter for ovens - 4 membranes PNC 922345
- Chimney adaptor PNC 922346
- Kit check valve PNC 922347
- Multipurpose hook PNC 922348

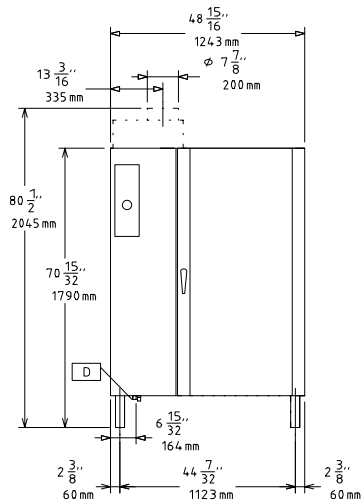
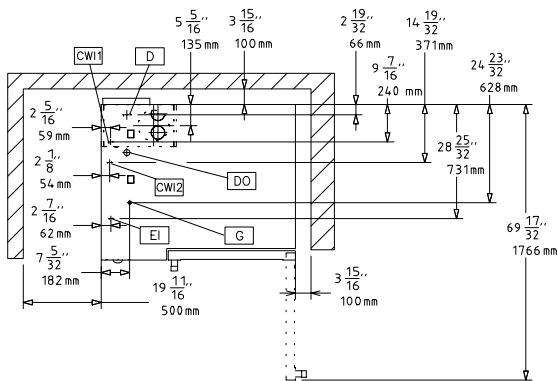

Front

Top

CW1 = Cold Water inlet
 CW2 = Cold Water Inlet 2
 D = Drain
 DO = Overflow drain pipe

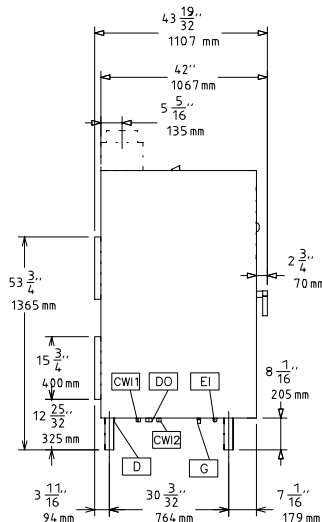
EI = Electrical connection
 G = Gas connection

Side

Electric

Supply voltage:
 267785 (AOS202GTW1) 230 V/1N ph/50/60 Hz

Electrical power, max: 2 kW

Circuit breaker required

Gas

ISO 7/1 gas connection diameter: 1" MNPT

Natural gas Pressure: 7" w.c. (17.4 mbar)

Steam generator: 55 kW

Heating elements: 187495 BTU/h (55 kW)

Total thermal load: 323855 BTU/h (95 kW)

Water

Water inlet "CW" connection: 3/4"

Total hardness: 5-50 ppm

Pressure, bar min/max: 1.5-4.5 bar

Drain "D": 2"

Electrolux recommends the use of treated water, based on testing of specific water conditions. Please refer to user manual for detailed water quality information.

Installation

Clearance: 5 cm rear and right hand sides.

Suggested clearance for service access: 50 cm left hand side.

Capacity

GN: 20 - 2/1 Gastronorm

GN: 40 - 1/1 containers

Max load capacity: 200 kg

Key Information

External dimensions, Height: 1795 mm

External dimensions, Width: 1243 mm

External dimensions, Depth: 1107 mm

Net weight: 414 kg

Shipping weight: 444 kg

Shipping volume: 3.1 m³